

NOTE :

For easy understanding, all isolation valves are not indicated on this drawing.

See accessories table.

Outdoor Sensor
(supplied with PHRIA)

Control box with ambient temperature sensor (supplied with PHRIA)

SA-1 Ambient sensor (if control box is outside zone 1)

Communication line

Communication line

FLOOR
(Heating only)

Zone 1

2 Zones - Floor + Radiators Low T°

Install thermostatic valve on all radiators low temperature

RADIATORS LOW T°

RADIATORS LOW T°

Zone 2

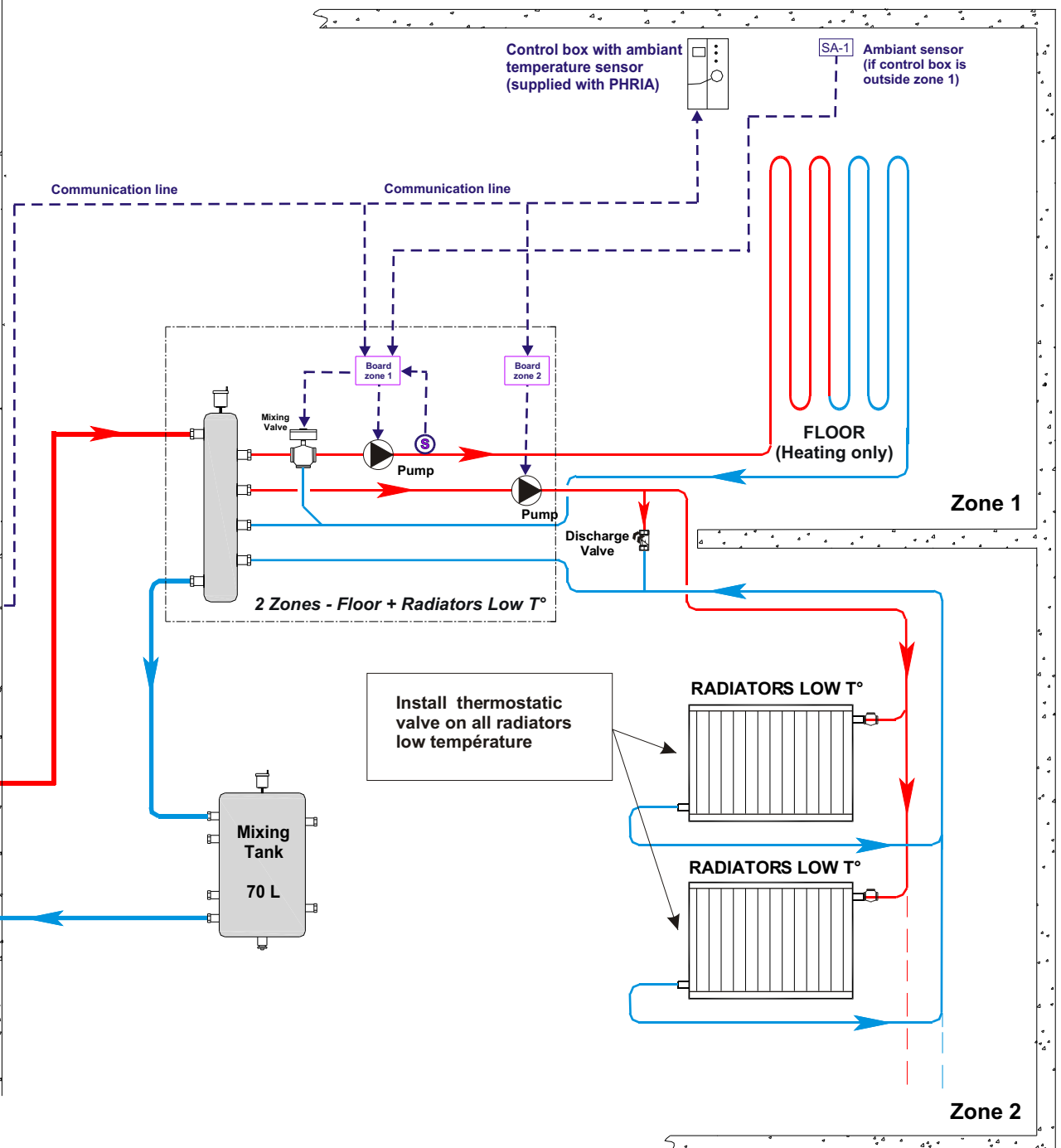
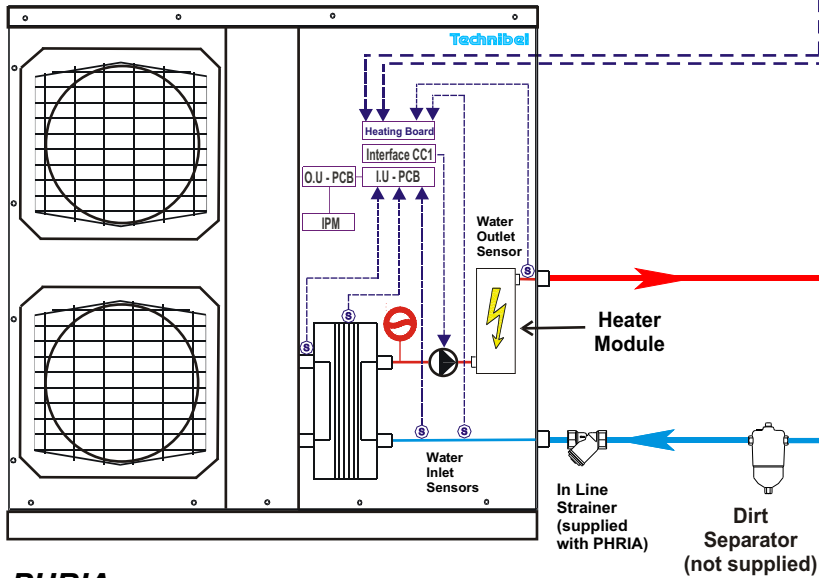

REV	DATE	MODIFICATION	DRG by	1097048G
00	27/01/2010	Creation	CP	

DRG by	DATE
CP	27/01/2010
CKD by	DATE
PB	